

Ø 305 mm  
Ø 12"

**VA90-BBL338P/N-94A**

**Technical Data**

All dimensions are expressed in mm. Use M6 screws for fixing - nominal tightening torque 4 Nm  
Motors certified **IP6K9K** and **IP68**

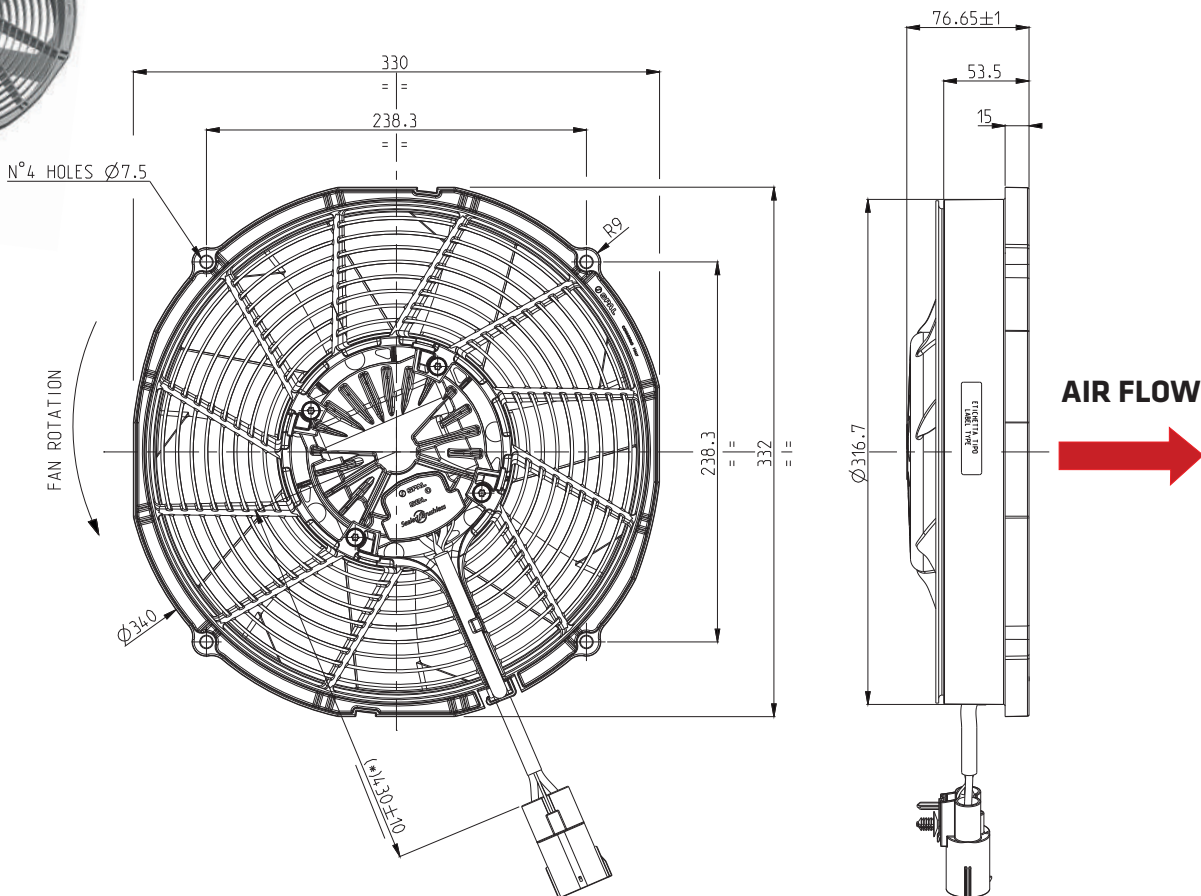

**Connector: YAZAKI HYBRID (USCAR-2 compliant) - Part number: 7282-8497-90**

	Identification	+	-	A	PWM* / E*
	Pin number	1	2	3	4
	Wire Color	RED	BLACK	YELLOW	WHITE
	Sealing p/n	7157-3582-90	7157-3582-90	7158-3030-50	7158-3030-50
	Pin p/n	7114-3251	7114-3251	7114-4102-02	7114-4102-02
	Section [mm <sup>2</sup> ]	4.0	4.0	0.5	0.5

**NOTE: YAZAKI connector counterpart available upon request (see page 63)**

## Performance Curve

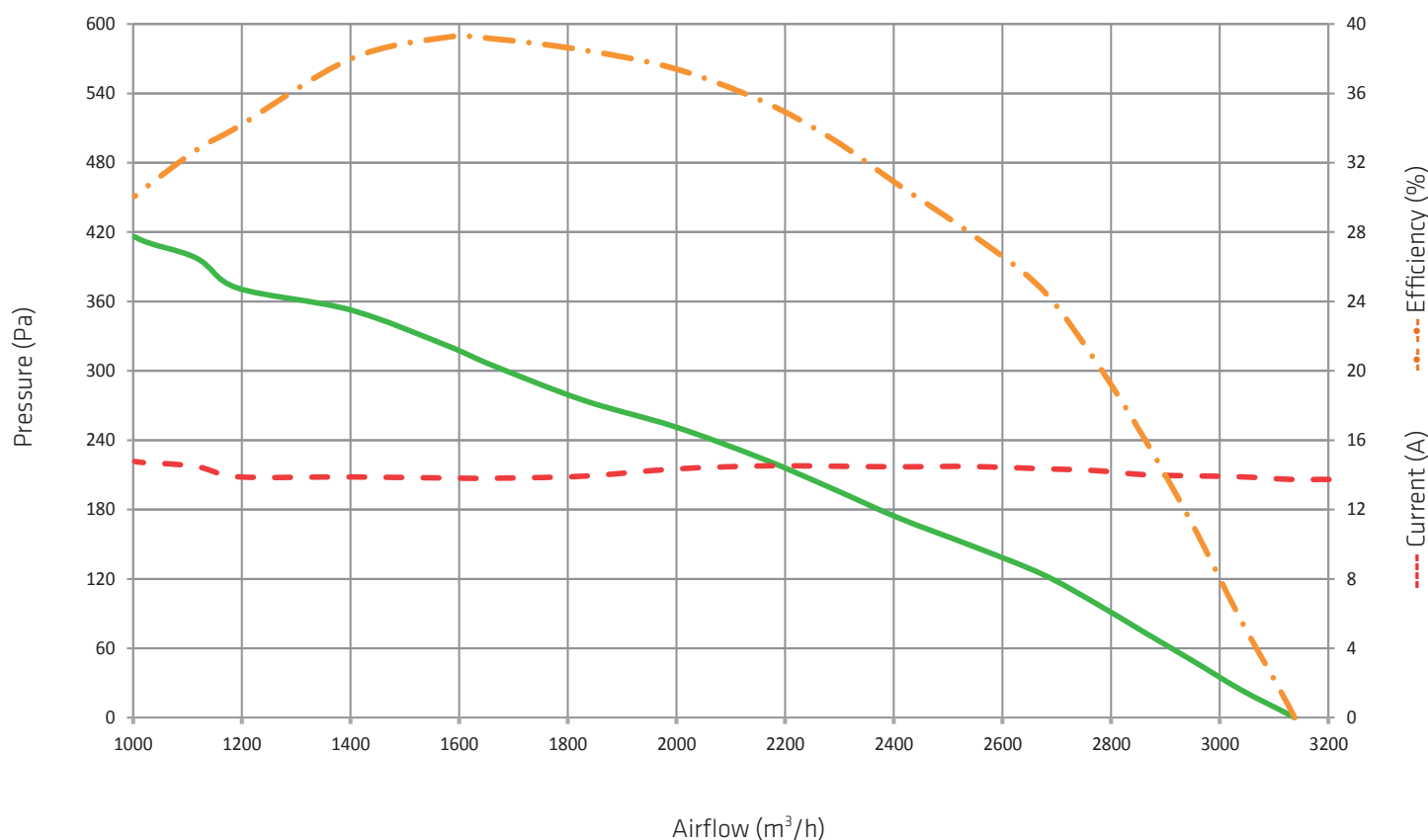
Pressure: 1Pa=0.004 inH<sub>2</sub>OAirflow: 1m<sup>3</sup>/h=0.59 cfm

## Features

<b>Max fan speed</b>	rpm	3650
<b>Min fan speed</b>	rpm	900
<b>Sound pressure level</b>	dBA	75.6 - at 1 m ± 0.005 m from the fan module- lateral side
<b>Weight</b>	Kg	2.4
<b>Operating supply voltage range</b>	V	16.0 .. 32.0 at the Drive Connector
<b>Supply voltage to reach max speed</b>	V	26.0 .. 32.0 at the Drive Connector
<b>Operating ambient temperature range</b>	°C	-40 .. +95
<b>Speed derating threshold</b>	°C	+85 (*)
<b>Storage temperature range</b>	°C	-40 .. +120
<b>Lifetime</b>	h	up to 40000 hours depending on mission profile
<b>Time from 0 rpm to max speed</b>	s	15
<b>Load dump protection (Pulse 5b)</b>	V	65 - Pulse peak voltage (U <sub>S</sub> *) - ISO16750-2:2010
<b>Reverse polarity protection</b>		ISO 16750-1 functional status class C - device fully functional after correcting the polarity

Notes (\*): Few minutes ambient temperature transients do not engage the derating owing to the thermal inertia of the system. Overloads may anticipate derating.